

# JM Stugor & Fritid

[info@jmstugor.se](mailto:info@jmstugor.se)

[www.jmstugor.se](http://www.jmstugor.se)

## HOT TUB MODELS



Explore. Design. Enjoy.

# Round Acrylic Hot Tubs



# Square Acrylic Hot Tubs

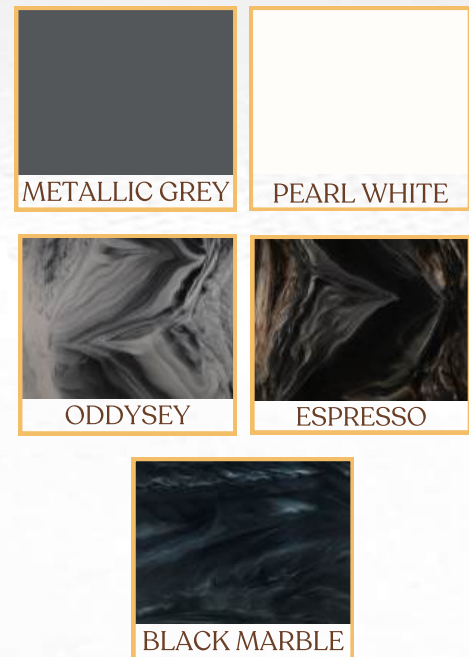

# Round Fiberglass Hot Tubs



SEMBA



SEMBA L



BARTIA



BARTIA L



VARMIA



VARMIA L

CREAM WHITE

SLATE GREY

SKY BLUE

METALLIC GREY

# Square Fiberglass Hot Tubs



CURONIA



OFURO HORIZON

CREAM WHITE

SLATE GREY

# One Seat Fiberglass Hot Tub



FRISK TUB

SKY BLUE

METALLIC GREY

# REVALIA

Round Acrylic 200 With  
Integrated Heater And Skimmer



External Width  
200 CM



Height  
100 CM



Internal Width  
175 CM

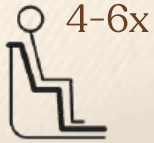

4-6x



25 KW



Color shown is approximate and may vary in person



Metallic Grey



White Pearl

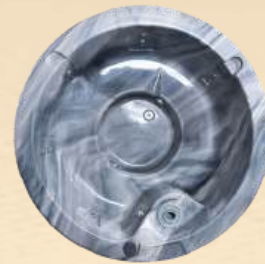

Odyssey



Espresso

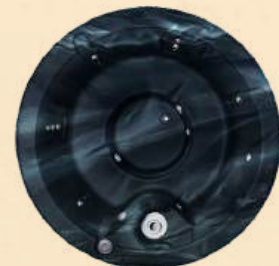

Black Marble

# MASSAGE SYSTEMS

Combi Hydro x 8 Jets + 4 x Air Jets

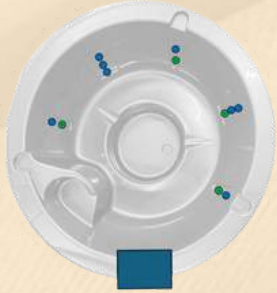

- BIG LED
- Mini LED
- Hydro
- Air
- Hydro 5"
- Hydro 3"
- Heater position

- Air Pump 0.7 KW
- Air Jets x 4
- Hydro Pump 1.1 KW
- Hydro Jets x 8

Hydro x 7 + 3 Med + 2 Big + 12 + Air Jets

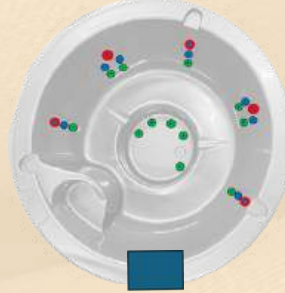

- BIG LED
- Mini LED
- Hydro
- Air
- Hydro 5"
- Hydro 3"
- Heater position

- Air Pump 0.7 KW
- Air Jets x 12
- Hydro Pump 1.5 KW
- Hydro Jets x 12

Hydro x 7 + 3 Med + 2 Big Jets

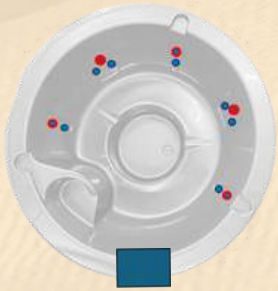

- BIG LED
- Mini LED
- Hydro
- Air
- Hydro 5"
- Hydro 3"
- Heater position

- Air Pump -
- Air Jets -
- Hydro Pump 1.5 KW
- Hydro Jets x 12

Combi Hydro x 12 Jets + Air x 12 + 10 ML + 1 Big



- BIG LED
- Mini LED
- Hydro
- Air
- Hydro 5"
- Hydro 3"
- Heater position

- Air Pump 0.7 KW
- Air Jets x 12
- Hydro Pump 1.5 KW
- Hydro Jets x 12

# MEASUREMENTS

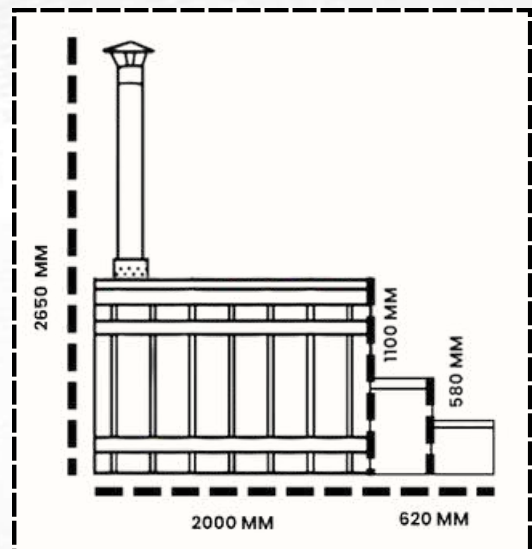
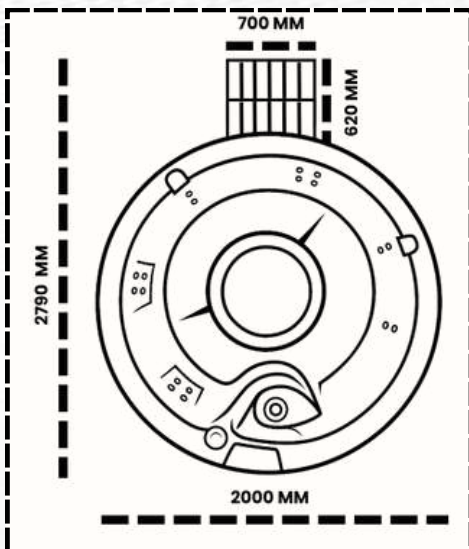

# SALVIA

Round Acrylic 200 With  
Integrated Heater And Skimmer



External Width  
200 CM



Height  
100 CM



Internal Width  
175 CM

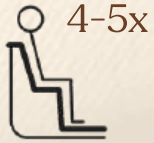

4-5x



30 KW



Color shown is approximate and may vary in person



Metallic Grey



White Pearl



Odyssey



Espresso



Black Marble

# MASSAGE SYSTEMS

Combi Hydro x 8 Jets + 4 x Air Jets



- BIG LED
- Mini LED
- Hydro
- Air
- Hydro 5"
- Hydro 3"
- Heater position

- Air Pump 0.7 KW
- Air Jets x 4
- Hydro Pump 1.1 KW
- Hydro Jets x 8

Hydro x 7 + 3 Med + 2 Big + 12 + Air Jets



- BIG LED
- Mini LED
- Hydro
- Air
- Hydro 5"
- Hydro 3"
- Heater position

- Air Pump 0.7 KW
- Air Jets x 12
- Hydro Pump 1.5 KW
- Hydro Jets x 12

Hydro x 7 + 3 Med + 2 Big Jets



- BIG LED
- Mini LED
- Hydro
- Air
- Hydro 5"
- Hydro 3"
- Heater position

- Air Pump -
- Air Jets -
- Hydro Pump 1.5 KW
- Hydro Jets x 12

Combi Hydro x 12 Jets + Air x 12 + 10 ML + 1 Big



- BIG LED
- Mini LED
- Hydro
- Air
- Hydro 5"
- Hydro 3"
- Heater position

- Air Pump 0.7 KW
- Air Jets x 12
- Hydro Pump 1.5 KW
- Hydro Jets x 12

# MEASUREMENTS

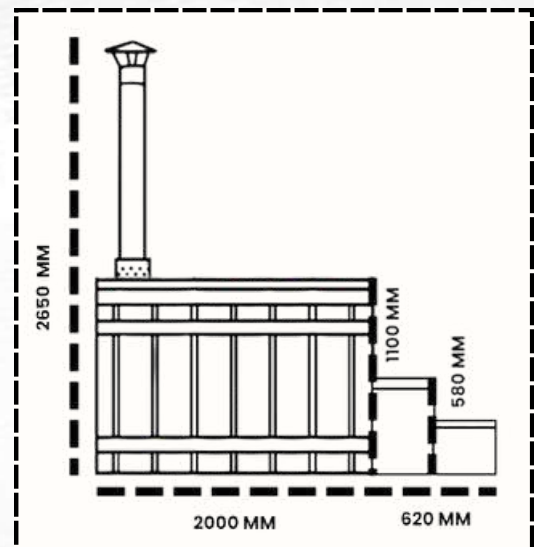
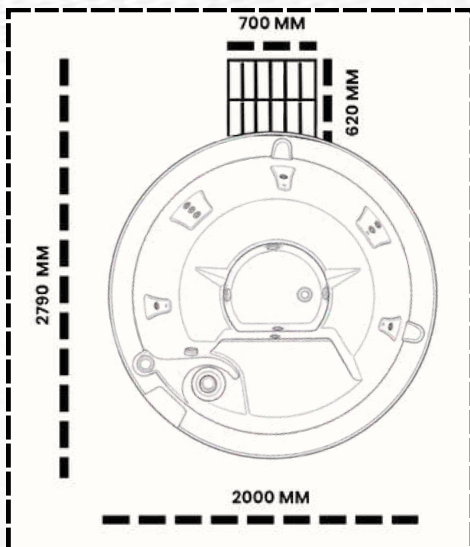

# TRUSSO

Round Acrylic 200 With  
Integrated Heater



External Width  
200 CM



Height  
85 CM



Internal Width  
180 CM



4-6x



30 KW



Color shown is approximate and may vary in person



Metallic Grey



White Pearl

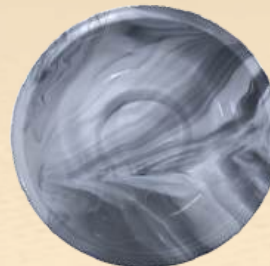

Odyssey



Espresso

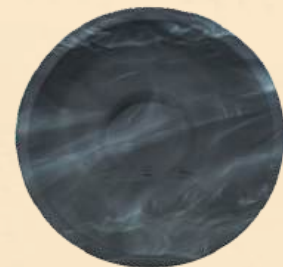

Black Marble

# MASSAGE SYSTEMS

**Hydro x 8 Jets**

- Air Pump -
- Air Jets -
- Hydro Pump 1.1 KW
- Hydro Jets x 8

**Air x 12 Jets**

- Air Pump 0.7 KW
- Air Jets x 12
- Hydro Pump -
- Hydro Jets -

**Combi Hydro x 22 Jets + Air x 4 Jets**

- Air Pump 0.7 KW
- Air Jets x 4
- Hydro Pump 1.5 KW
- Hydro Jets x 22

**Combi Hydro x 8 Jets + Air x 4 Jets**

- Air Pump 0.7 KW
- Air Jets x 4
- Hydro Pump 1.1 KW
- Hydro Jets x 8

**Hydro x 8 Jets + Air x 12 Jets**

- Air Pump 0.7 KW
- Air Jets x 12
- Hydro Pump 1.1 KW
- Hydro Jets x 8

# MEASUREMENTS

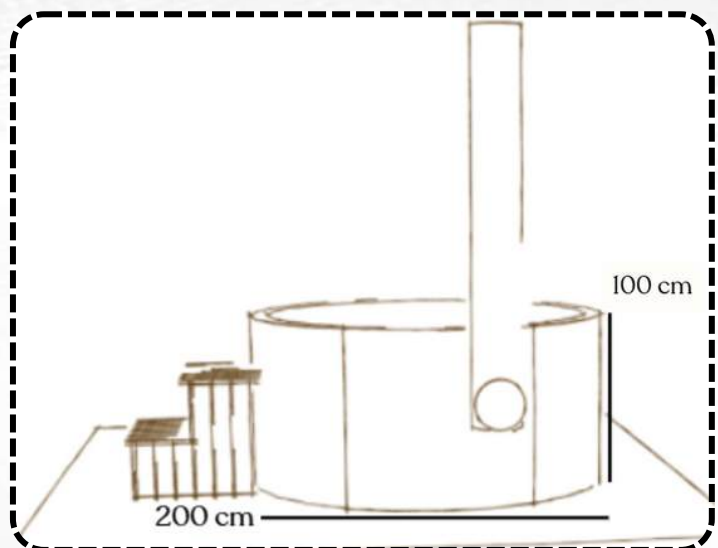
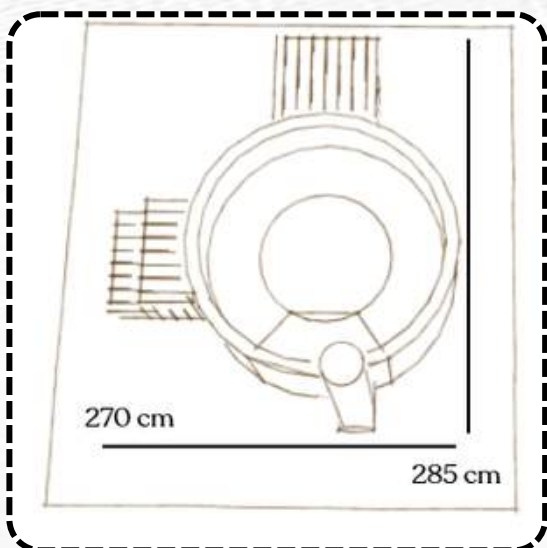

# GALINDA

Round Acrylic 200 With  
Integrated Heater



External Width  
200 CM



Height  
85 CM



Internal Width  
180 CM

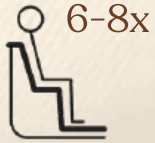

6-8x



25 KW



Color shown is approximate and may vary in person



Metallic Grey



White Pearl

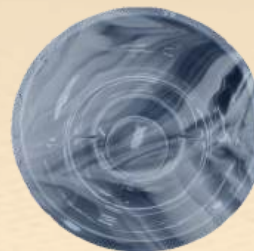

Odyssey

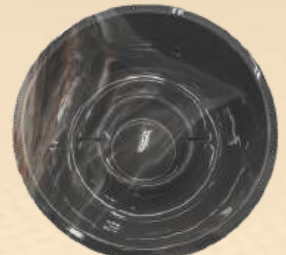

Espresso

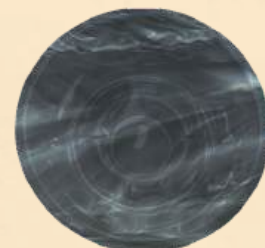

Black Marble



# MASSAGE SYSTEMS

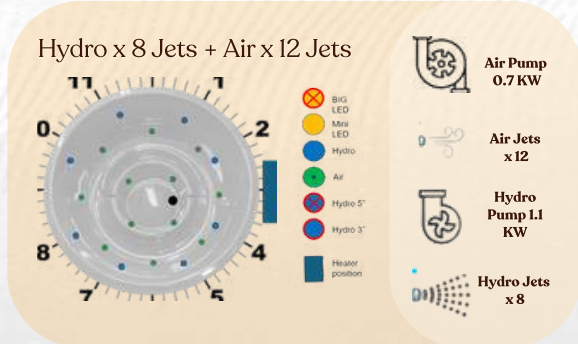
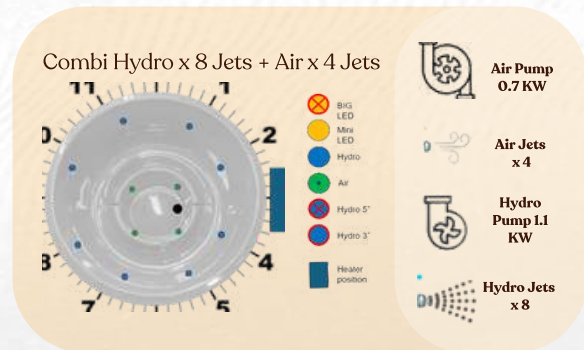
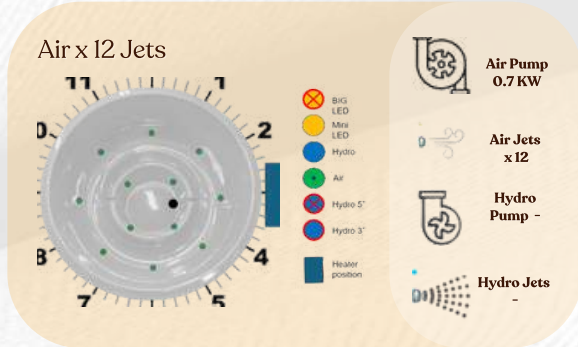
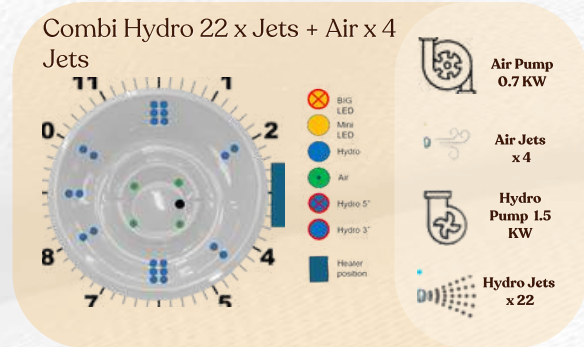
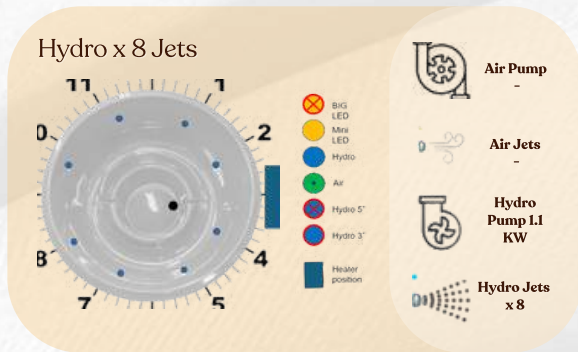

# MEASUREMENTS

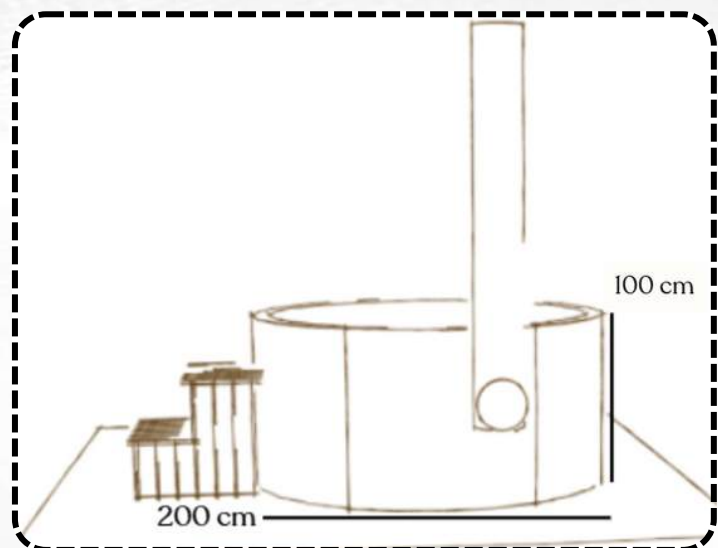
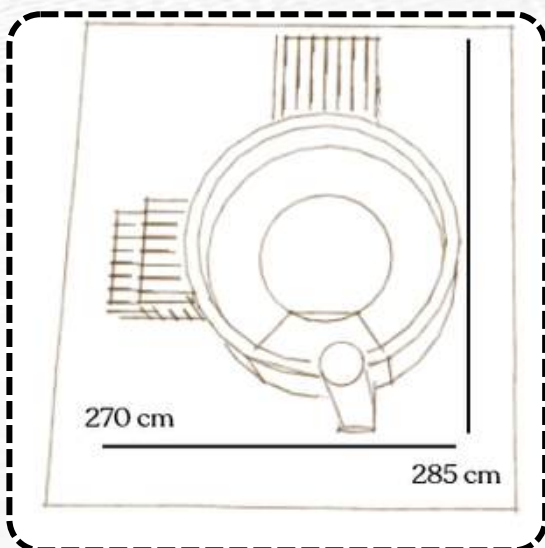

# NOTANGA

Round Acrylic 200 With  
External Heater



External Width  
200 CM



Height  
85 CM



Internal Width  
180 CM

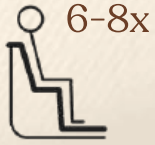

6-8x



25 KW



Color shown is approximate and may vary in person



Metallic Grey



White Pearl

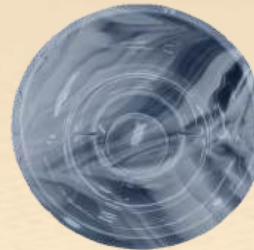

Odyssey

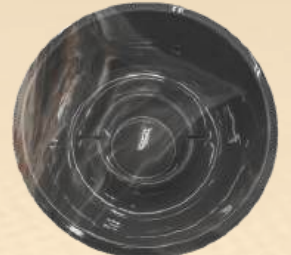

Espresso

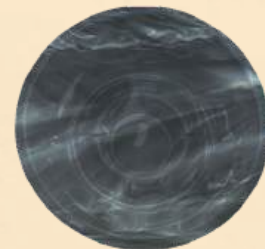

Black Marble

# MASSAGE SYSTEMS

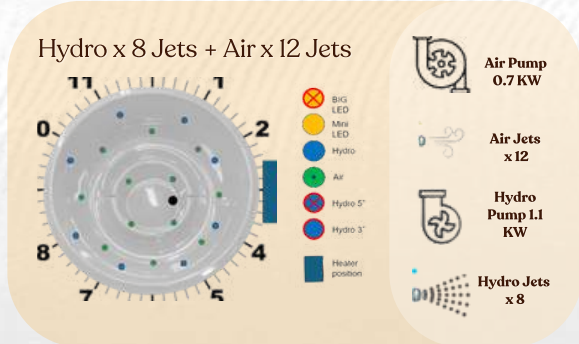
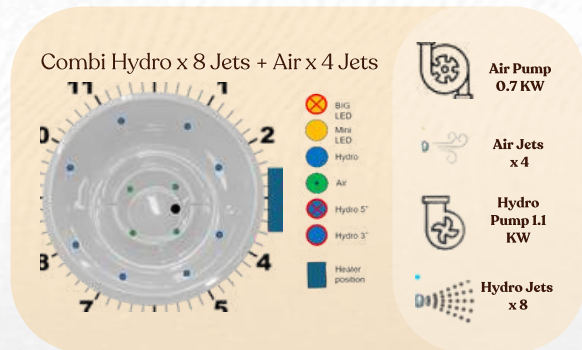
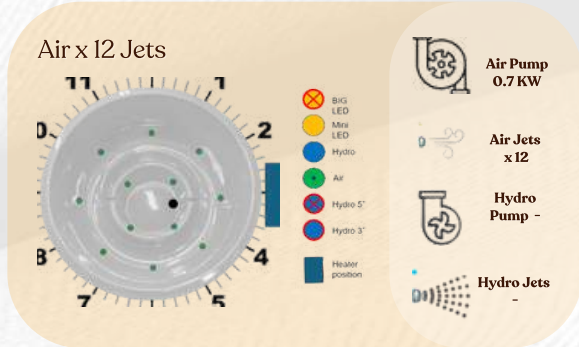
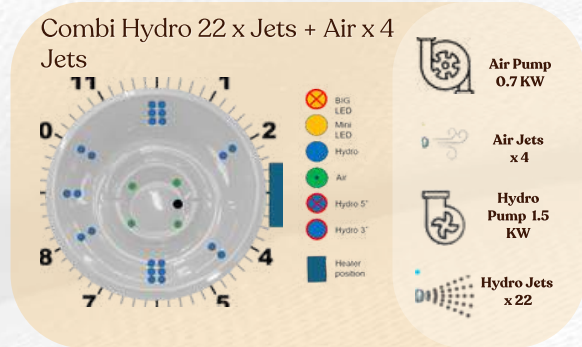
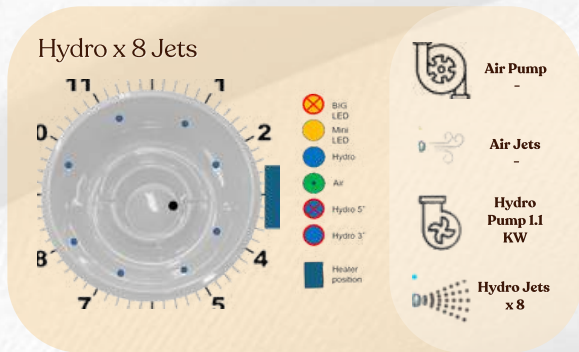

# MEASUREMENTS

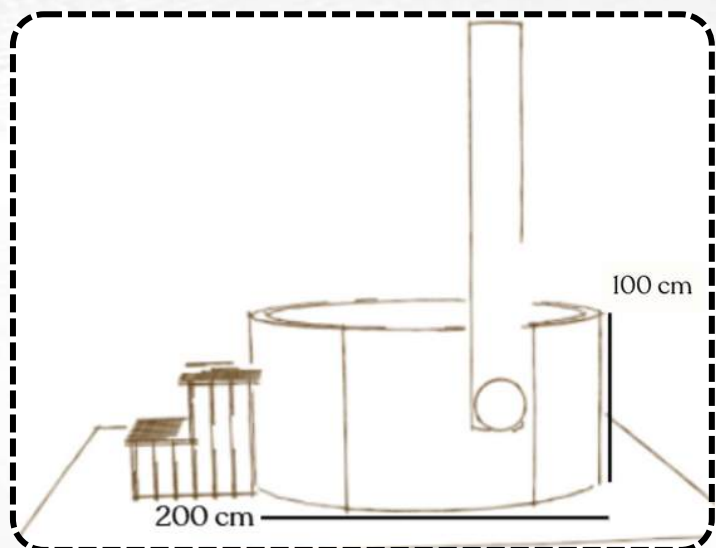
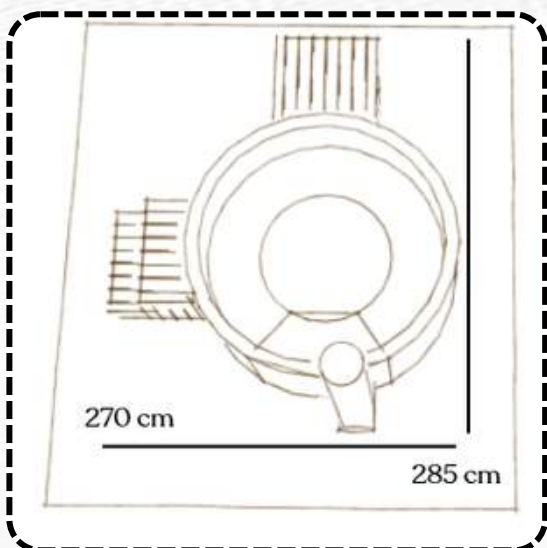

# ROMOWE

Square Acrylic 202 x 202 With  
Integrated/External Heater



External Width  
202x202 CM



Height  
100 CM



Internal Width  
182x182 CM



8-10x



25 KW



Color shown is approximate and may vary in person



Metallic Grey



White Pearl



Odyssey

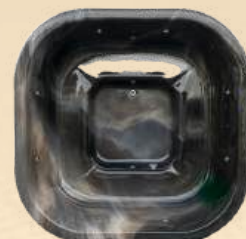

Espresso



Black Marble

# MASSAGE SYSTEMS

Combi Hydro x 8 Jets + Air x 4 Jets

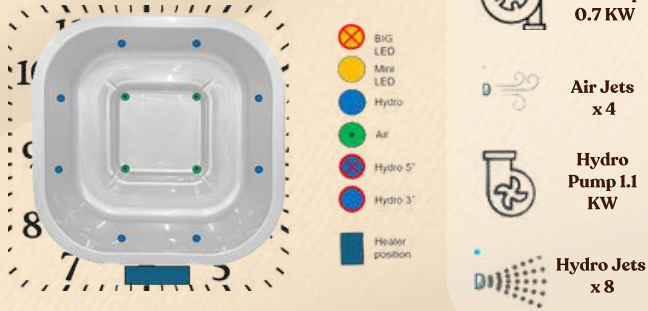

Combi Hydro x 22 Jets + Air x 4 Jets

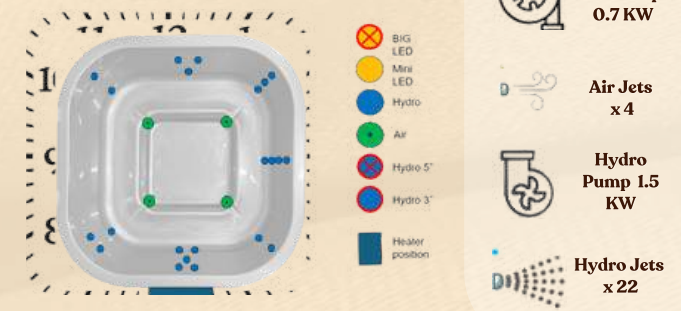

Combi Hydro x 18 Jets + 4 Big Hydro Jets + Air x 4 Jets

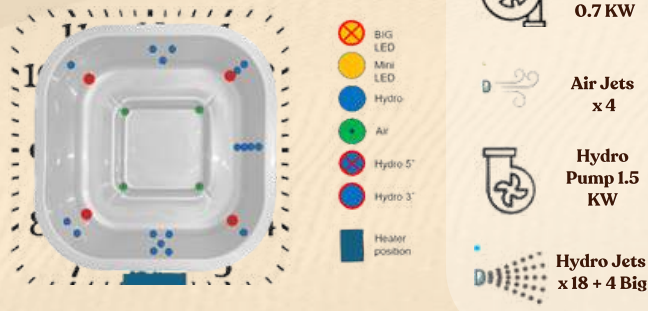

Hydro x 8 Jets



# MEASUREMENTS

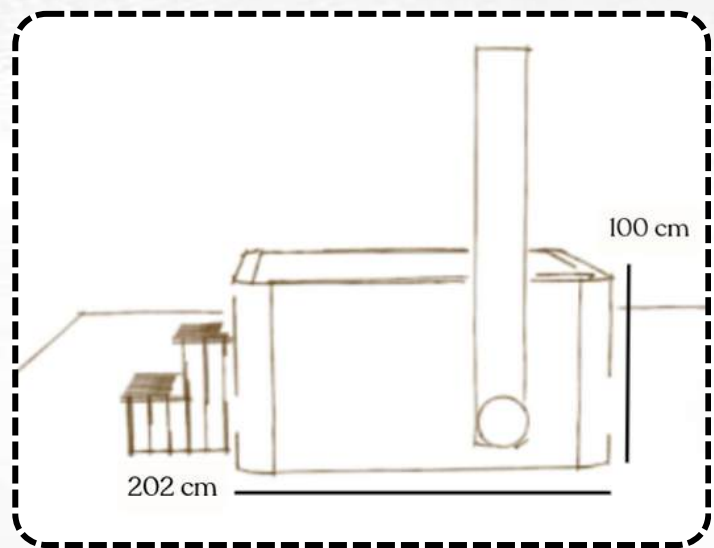
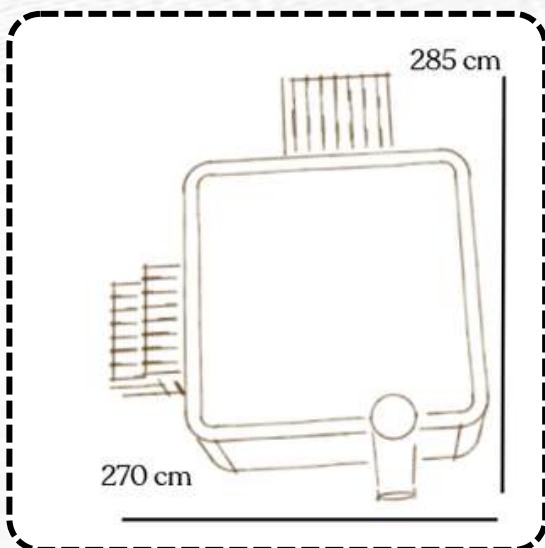

# BRUGIA

Square Acrylic 204 x 204 With  
Integrated Heater



External Width  
204x204 CM



Height  
100 CM



Internal Width  
180x180 CM



6x



25 KW



Color shown is approximate and may vary in person



Metallic Grey



White Pearl



Odyssey



Espresso



Black Marble



# MASSAGE SYSTEMS

Hydro x 13 Jets + 3 Big Jets + Air x 12



- BIG LED
- Mini LED
- Hydro
- Air
- Hydro 5"
- Hydro 3"
- Heater position



**Air Pump**  
0.7 KW



**Air Jets**  
x 12



**Hydro Pump**  
1.5 KW



**Hydro Jets**  
x 13 + 3 Big

Air x 14 Jets



- BIG LED
- Mini LED
- Hydro
- Air
- Hydro 5"
- Hydro 3"
- Heater position



**Air Pump**  
0.7 KW



**Air Jets**  
x 14



**Hydro Pump**  
-



**Hydro Jets**  
-

Hydro x 13 Jets + 3 Big Jets



- BIG LED
- Mini LED
- Hydro
- Air
- Hydro 5"
- Hydro 3"
- Heater position



**Air Pump**  
-



**Air Jets**  
-



**Hydro Pump**  
1.5 KW



**Hydro Jets**  
x 13 + 3 Big

# MEASUREMENTS

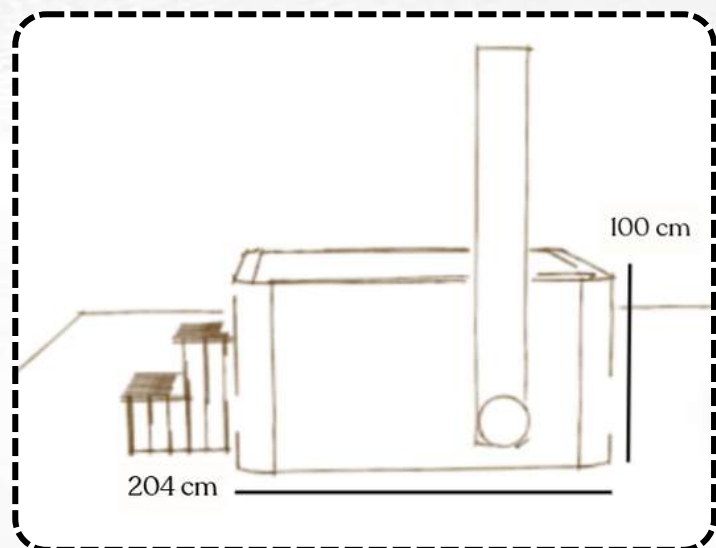
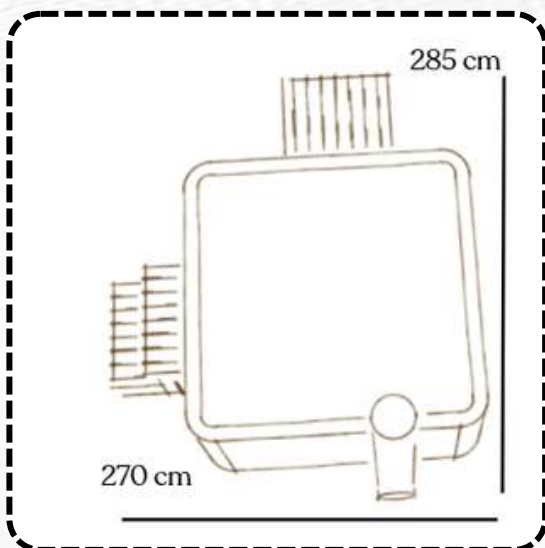

# SEMBA

Round Fiberglass 200  
With Integrated Heater



External Width  
200 CM



Height  
85 CM



Internal Width  
180 CM

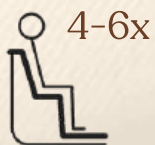

4-6x



30 KW



Color shown is approximate and may vary in person



Cream White



Slate Grey



Sky Blue



Metallic Grey

# MASSAGE SYSTEMS

**Hydro x 8 Jets**

Air Pump -  
 Air Jets -  
 Hydro Pump 1.1 KW  
 Hydro Jets x 8

**Air x 12 Jets**

Air Pump 0.7 KW  
 Air Jets x 12  
 Hydro Pump -  
 Hydro Jets -

**Combi Hydro x 22 Jets + Air x 4 Jets**

Air Pump 0.7 KW  
 Air Jets x 4  
 Hydro Pump 1.5 KW  
 Hydro Jets x 22

**Combi Hydro x 8 Jets + Air x 4 Jets**

Air Pump 0.7 KW  
 Air Jets x 4  
 Hydro Pump 1.1 KW  
 Hydro Jets x 8

# MEASUREMENTS

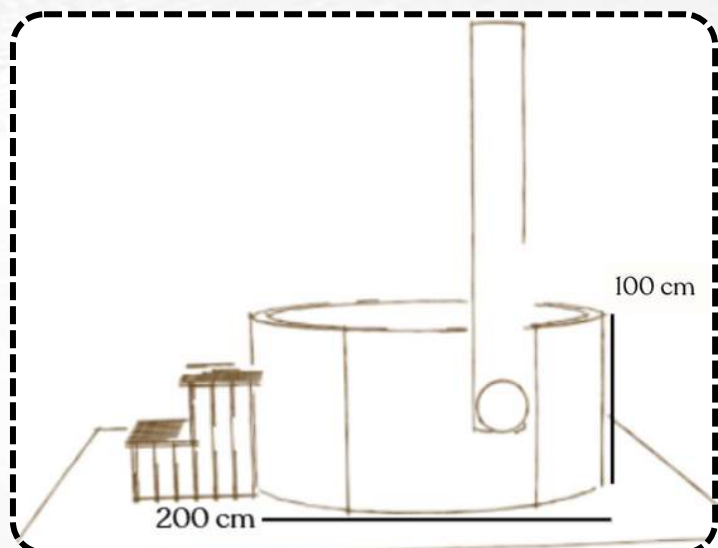
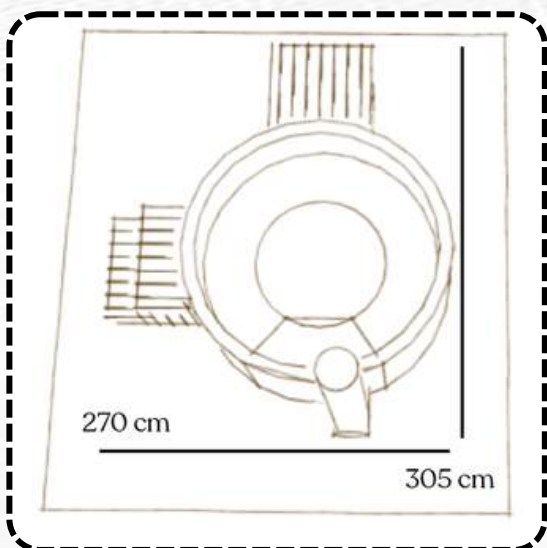

# SEMBA L

Round Fiberglass 225  
With Integrated Heater



External Width  
225 CM



Height  
90 CM



Internal Width  
205 CM

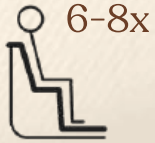

6-8x



30 KW



Color shown is approximate and may vary in person



Cream White



Slate Grey



Sky Blue



Metallic Grey



# MASSAGE SYSTEMS

Hydro x 8 Jets

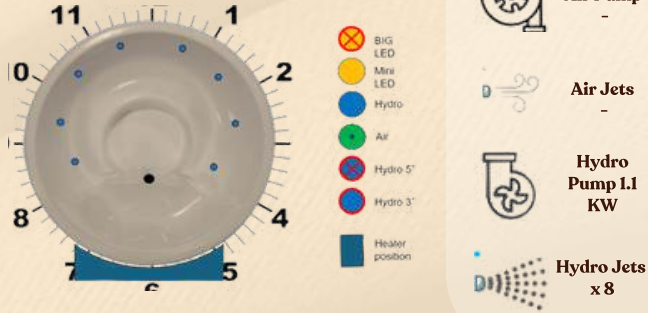

Air x 12 Jets

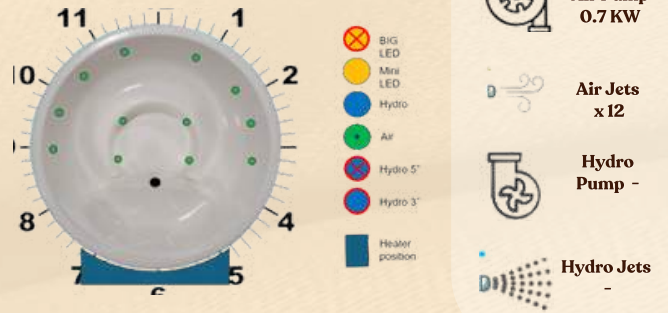

Combi Hydro x 22 Jets + Air x 4 Jets

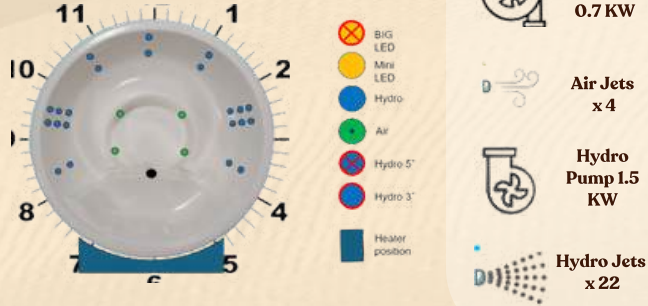

Combi Hydro x 8 Jets + Air x 4 Jets

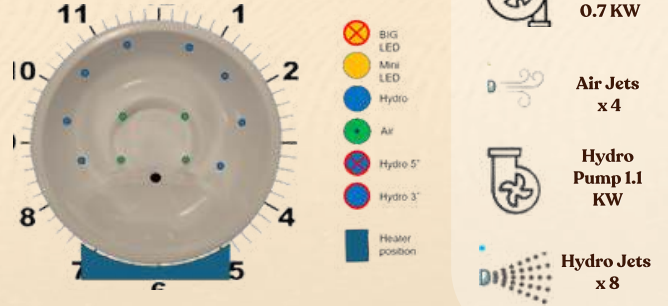

# MEASUREMENTS

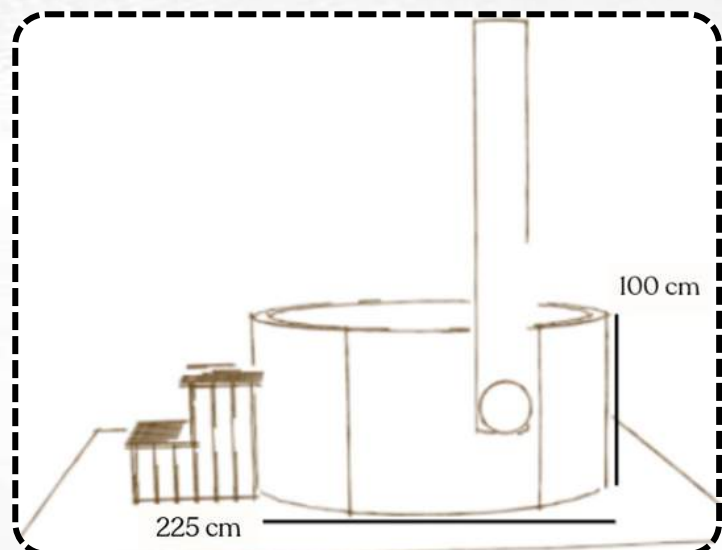
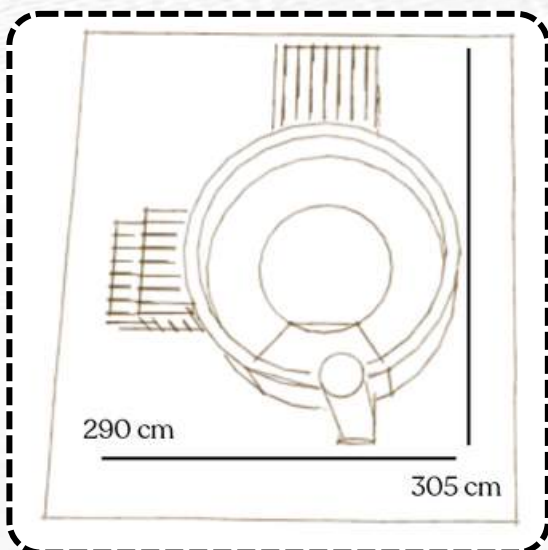

# BARTIA

Round Fiberglass 200  
With Integrated Heater



External Width  
200 CM



Height  
85 CM



Internal Width  
180 CM

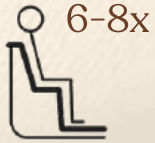

6-8x



25 KW



Color shown is approximate and may vary in person



Cream White



Slate Grey



Sky Blue



Metallic Grey



# MASSAGE SYSTEMS

**Hydro x 8 Jets**

- Big LED
- Mini LED
- Hydro
- Air
- Hydro 5"
- Hydro 3"
- Heater position

- Air Pump -
- Air Jets -
- Hydro Pump 1.1 KW
- Hydro Jets x 8

**Air x 12 Jets**

- Big LED
- Mini LED
- Hydro
- Air
- Hydro 5"
- Hydro 3"
- Heater position

- Air Pump 0.7 KW
- Air Jets x 12
- Hydro Pump -
- Hydro Jets -

**Combi Hydro x 22 Jets + Air x 4 Jets**

- Big LED
- Mini LED
- Hydro
- Air
- Hydro 5"
- Hydro 3"
- Heater position

- Air Pump 0.7 KW
- Air Jets x 4
- Hydro Pump 1.5 KW
- Hydro Jets x 22

**Combi Hydro x 8 Jets + Air x 4 Jets**

- Big LED
- Mini LED
- Hydro
- Air
- Hydro 5"
- Hydro 3"
- Heater position

- Air Pump 0.7 KW
- Air Jets x 4
- Hydro Pump 1.1 KW
- Hydro Jets x 8

**Hydro x 8 Jets + Air x 12 Jets**

- Big LED
- Mini LED
- Hydro
- Air
- Hydro 5"
- Hydro 3"
- Heater position

- Air Pump 0.7 KW
- Air Jets x 12
- Hydro Pump 1.1 KW
- Hydro Jets x 8

# MEASUREMENTS

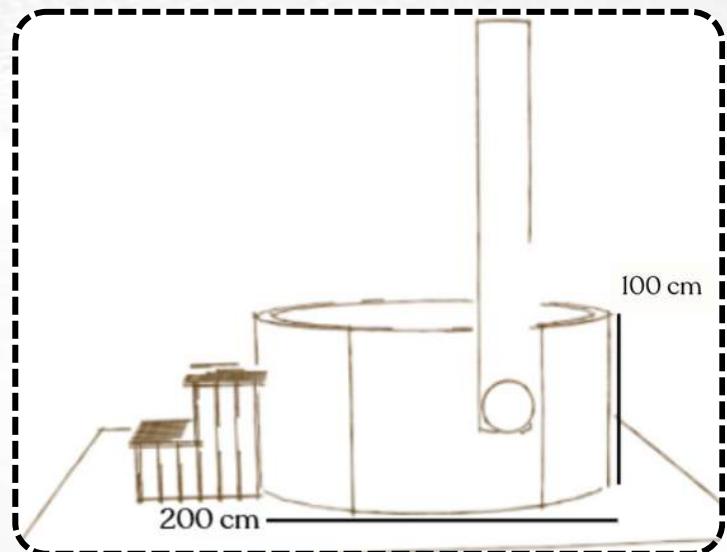
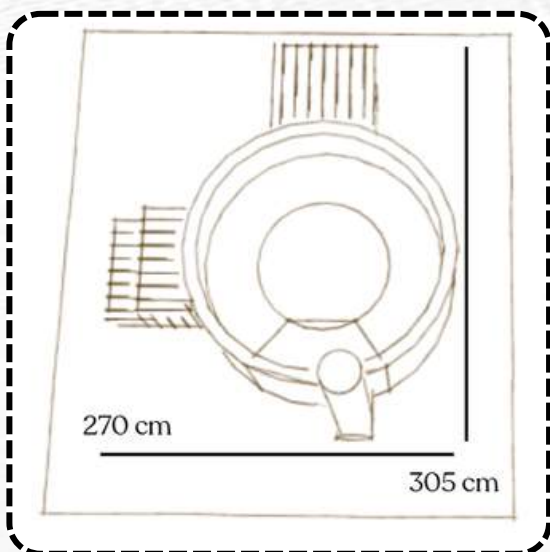

# BARTIAL

Round Fiberglass 225  
With Integrated Heater



External Width  
225 CM



Height  
90 CM



Internal Width  
205 CM



Color shown is approximate and may vary in person



Cream White



Slate Grey



Sky Blue



Metallic Grey

# MASSAGE SYSTEMS

**Hydro x 8 Jets**

- BIG LED
- Mini LED
- Hydro
- Air
- Hydro 5"
- Hydro 3"
- Heater position

- Air Pump -
- Air Jets -
- Hydro Pump 1.1 KW
- Hydro Jets x 8

**Air x 12 Jets**

- BIG LED
- Mini LED
- Hydro
- Air
- Hydro 5"
- Hydro 3"
- Heater position

- Air Pump 0.7 KW
- Air Jets x 12
- Hydro Pump -
- Hydro Jets -

**Combi Hydro x 18 Jets + 4 Big Hydro Jets + Air x 4 Jets**

- BIG LED
- Mini LED
- Hydro
- Air
- Hydro 5"
- Hydro 3"
- Heater position

- Air Pump 0.7 KW
- Air Jets x 4
- Hydro Pump 1.5 KW
- Hydro Jets x 18 + 4 Big

**Combi Hydro x 8 Jets + Air x 4 Jets**

- BIG LED
- Mini LED
- Hydro
- Air
- Hydro 5"
- Hydro 3"
- Heater position

- Air Pump 0.7 KW
- Air Jets x 4
- Hydro Pump 1.1 KW
- Hydro Jets x 8

**Hydro x 8 Jets + Air x 12 Jets**

- BIG LED
- Mini LED
- Hydro
- Air
- Hydro 5"
- Hydro 3"
- Heater position

- Air Pump 0.7 KW
- Air Jets x 12
- Hydro Pump 1.1 KW
- Hydro Jets x 8

# MEASUREMENTS

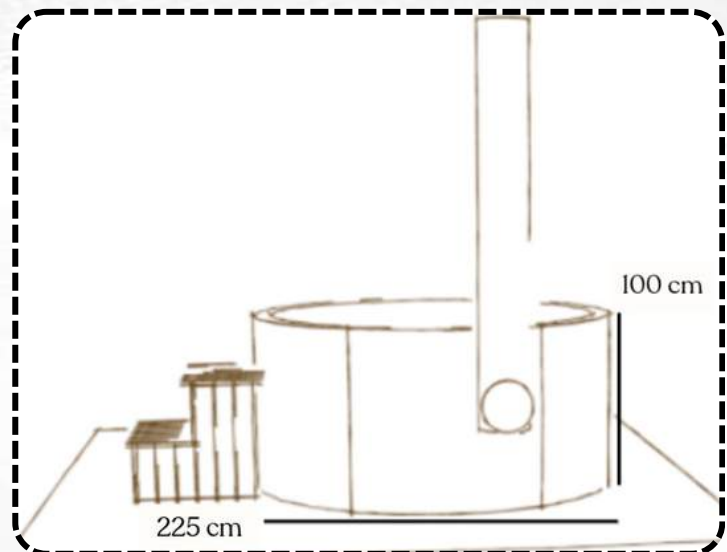
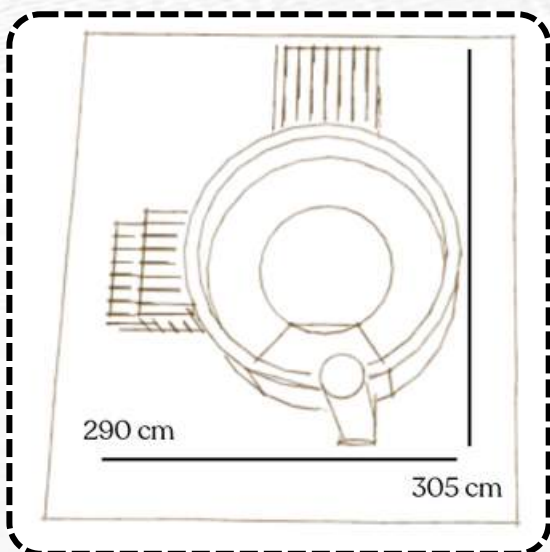

# VARMIA

Round Fiberglass 200  
With External Heater



External Width  
200 CM



Height  
85 CM



Internal Width  
180 CM

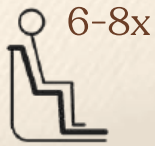

6-8x



20 KW

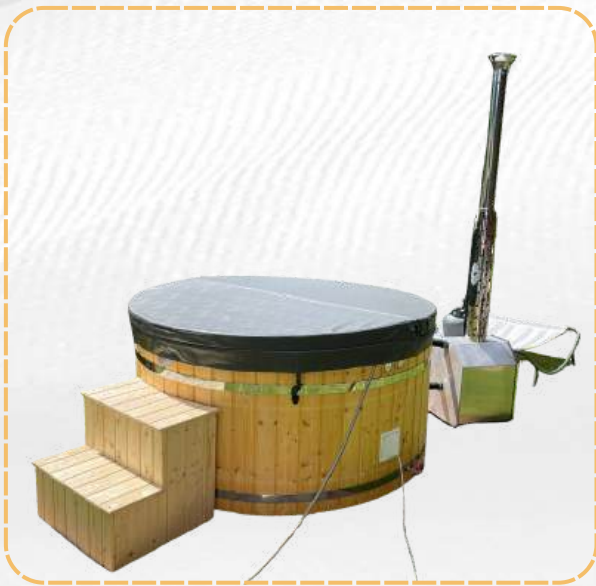

Color shown is approximate and may vary in person



Cream White



Slate Grey



Sky Blue



Metallic Grey

# MASSAGE SYSTEMS

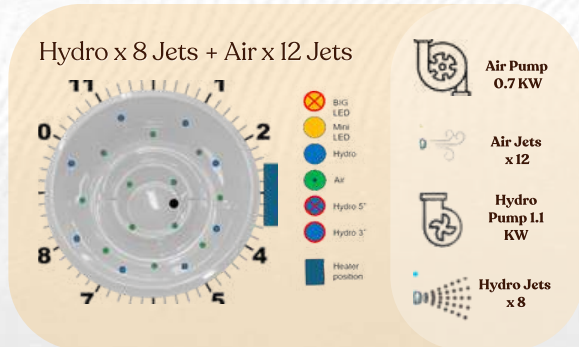
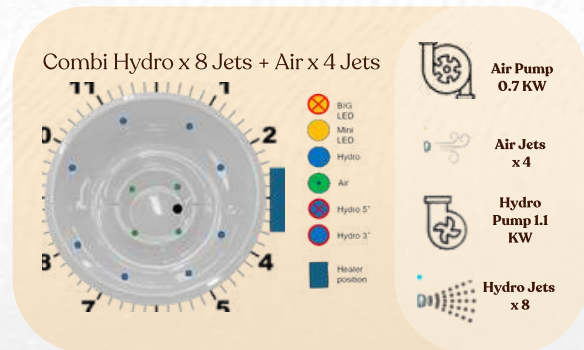
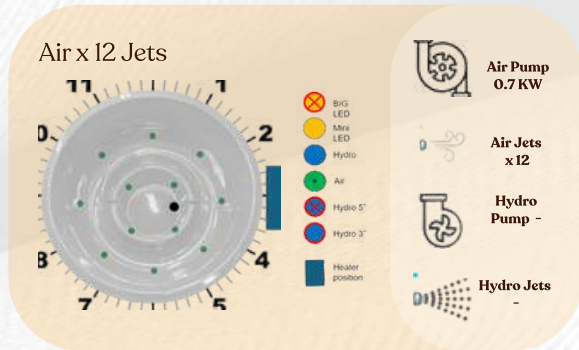
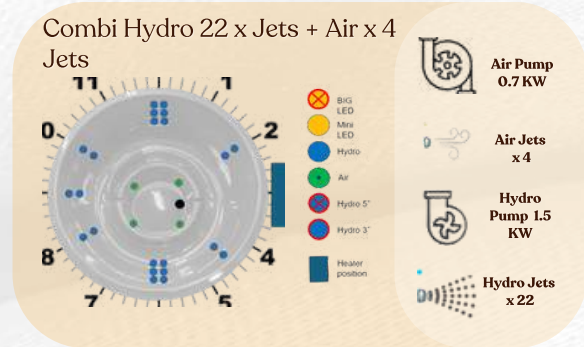
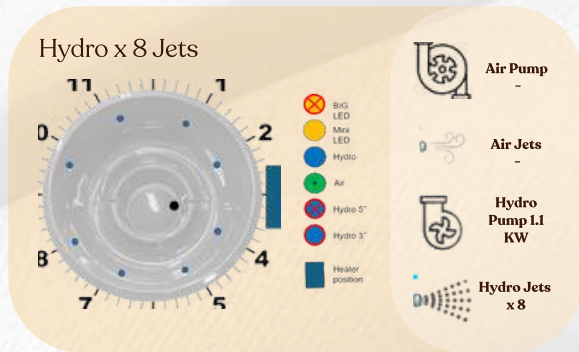

# MEASUREMENTS

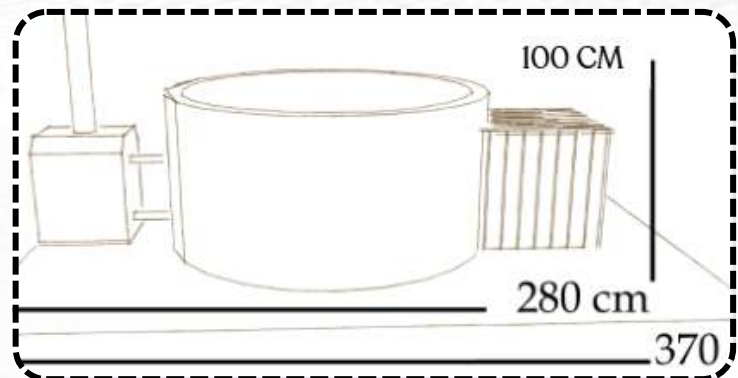
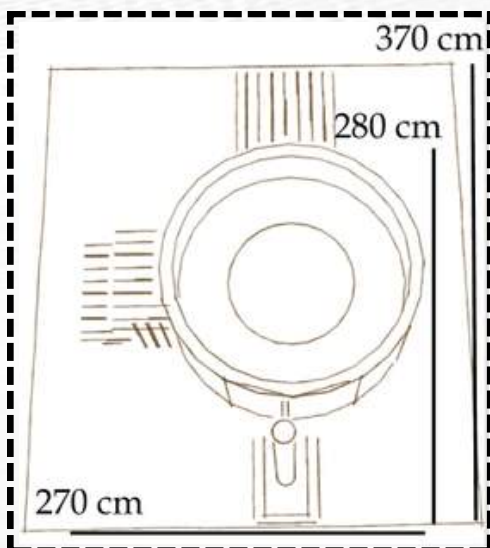

# VARMIA L

Round Fiberglass 255  
With External Heater



External Width  
255 CM



Height  
90 CM



Internal Width  
205 CM

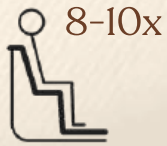

8-10x



20 KW



Color shown is approximate and may vary in person



Cream White



Slate Grey



Sky Blue



Metallic Grey

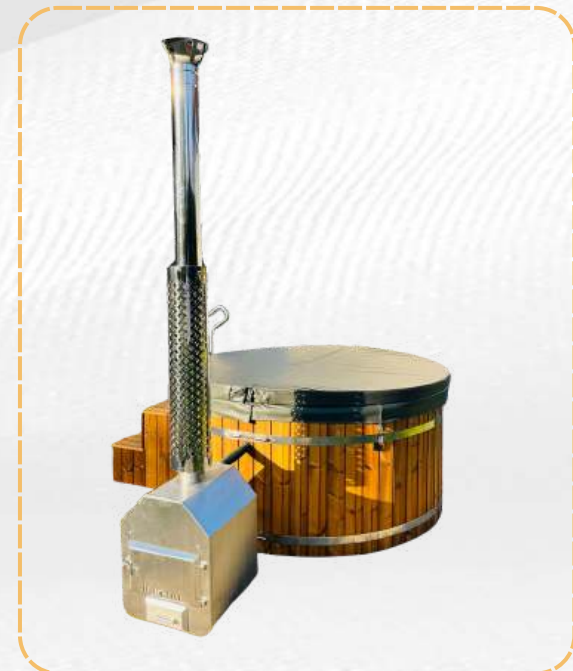

# MASSAGE SYSTEMS

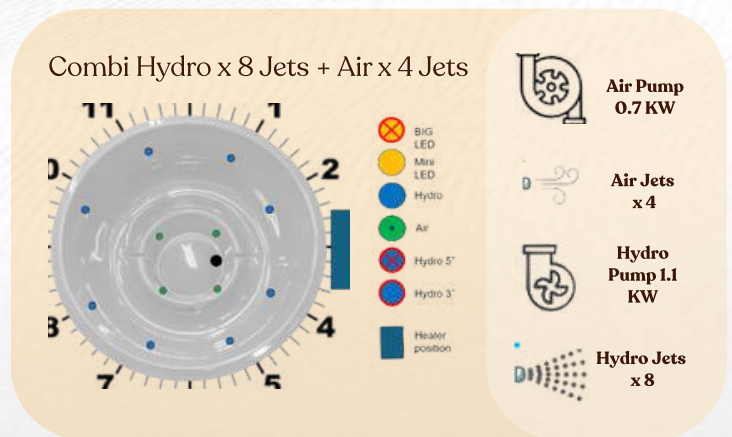
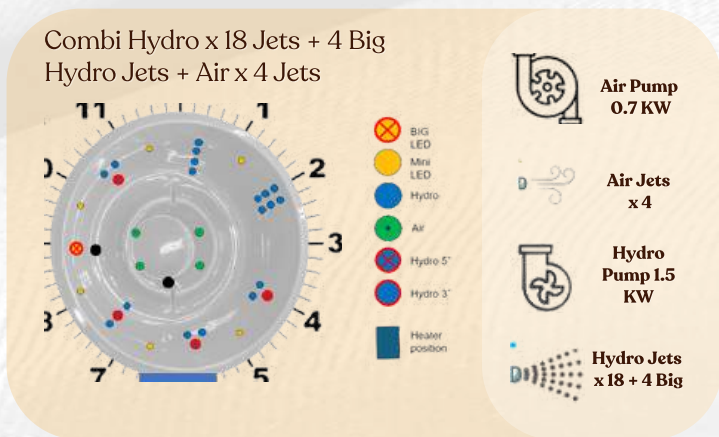
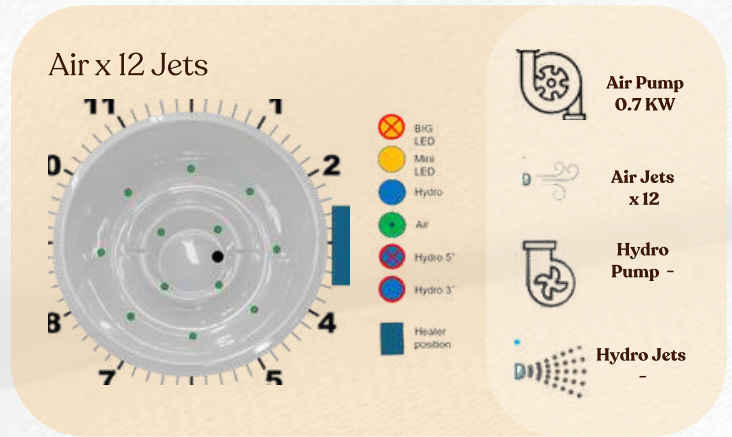
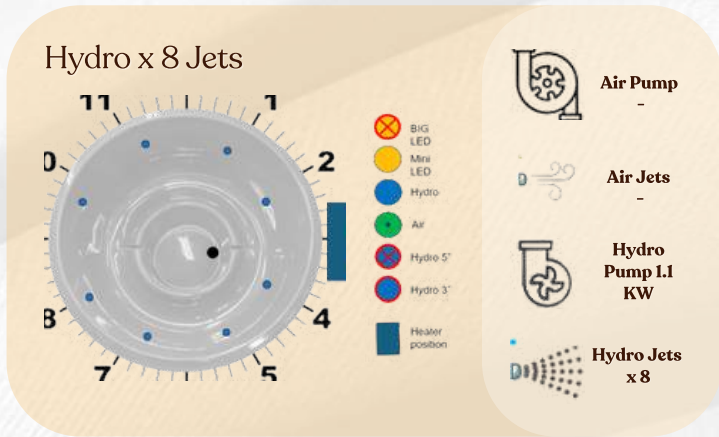

# MEASUREMENTS

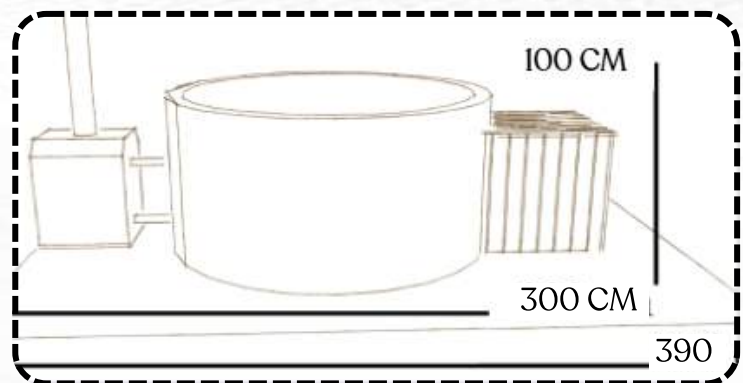
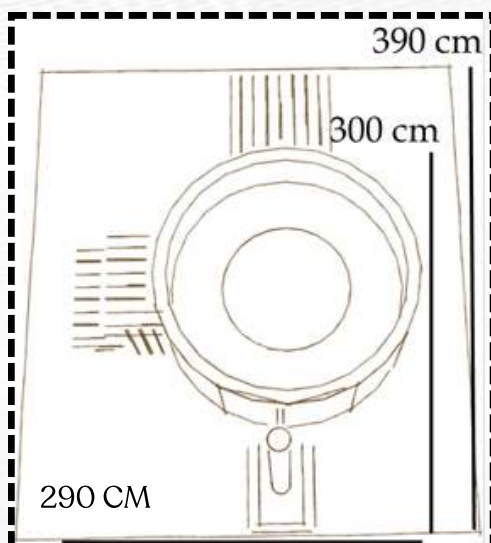

# CURONIA

Square Fiberglass 202x202  
With Internal Heater



External Width  
202x202 CM



Height  
100 CM



Internal Width  
182x182 CM

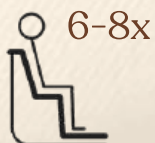

6-8x



25 KW



Color shown is approximate and may vary in person



Cream White

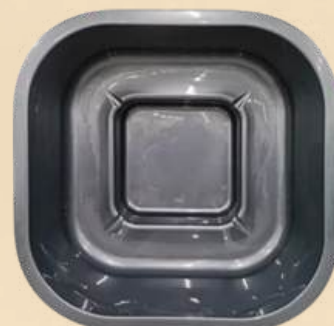

Slate Grey



Sky Blue



Metallic Grey

# MASSAGE SYSTEMS

Combi Hydro x 8 Jets + Air x 4 Jets

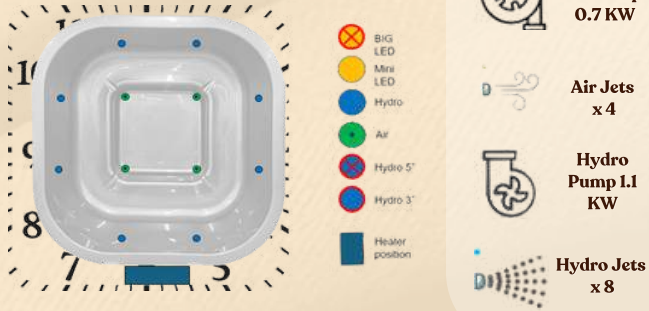

Combi Hydro x 22 Jets + Air x 4 Jets

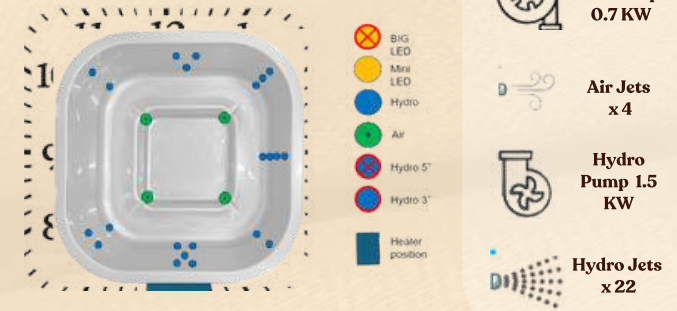

Combi Hydro x 18 Jets + 4 Big Hydro Jets + Air x 4 Jets



Hydro x 8 Jets



# MEASUREMENTS

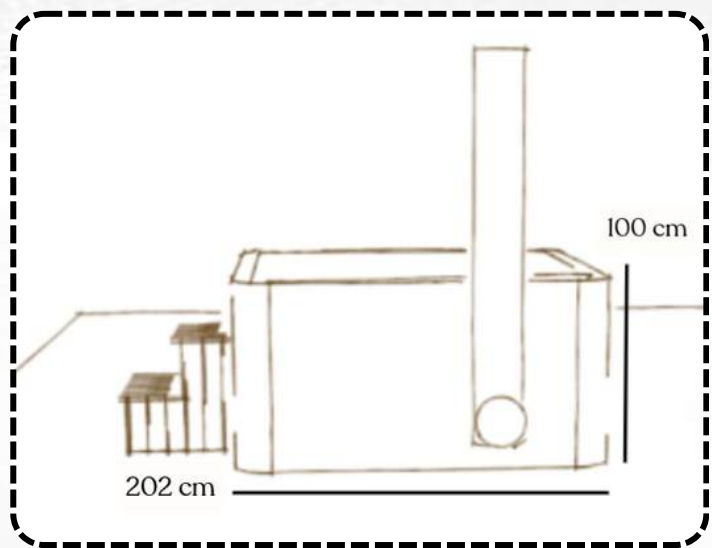
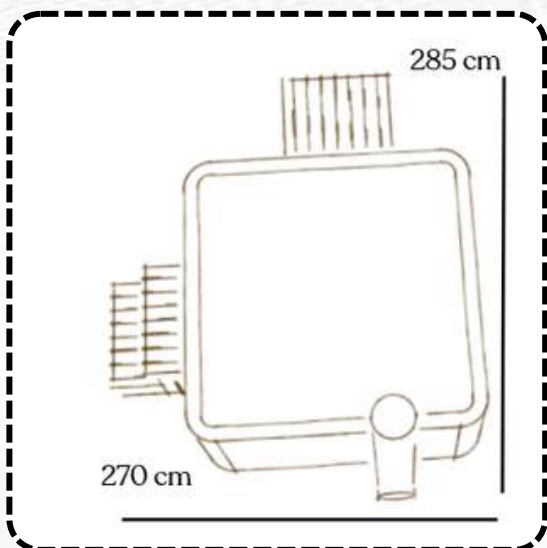

# OFURO HORIZON

Round Fiberglass 200  
With Integrated Heater



External Width  
200x120 CM



Height  
107 CM



Internal Width  
180x100 CM



1-2x



20 KW



Color shown is approximate and may vary in person



# MASSAGE SYSTEMS

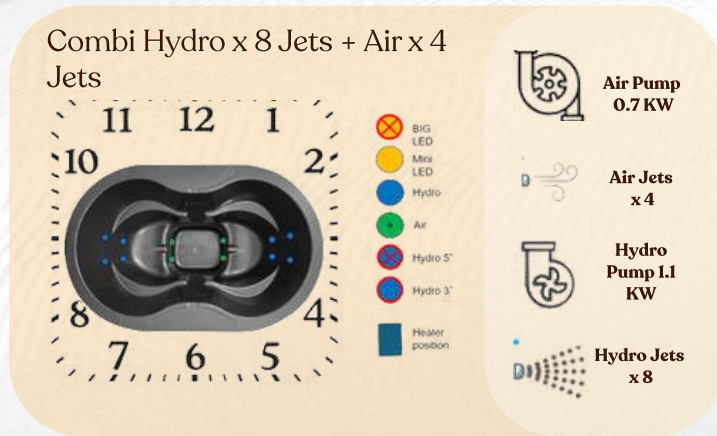
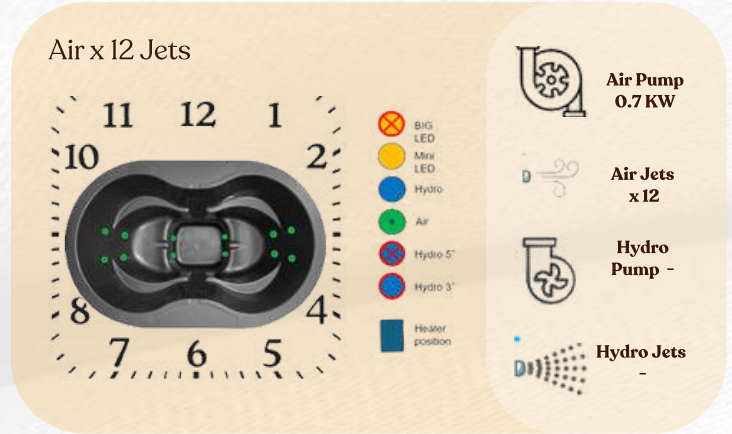
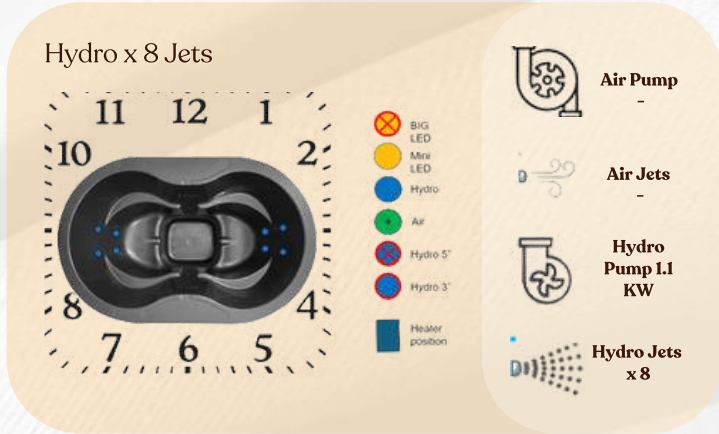

# MEASUREMENTS

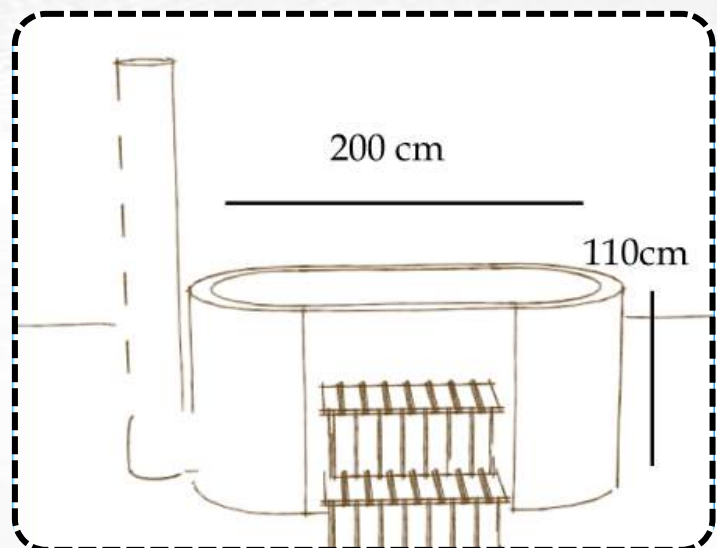
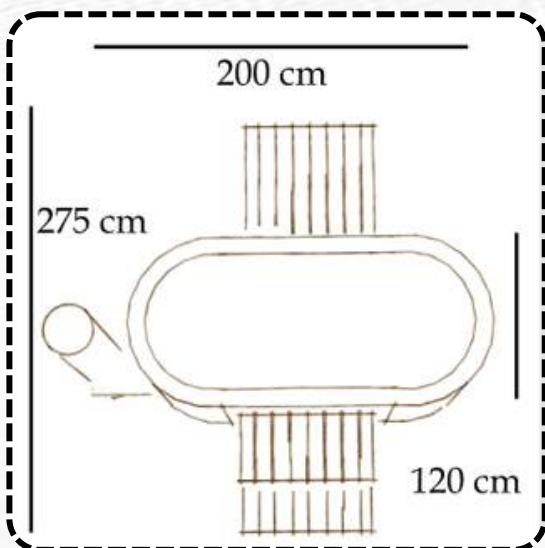

# FRISK TUB

Round Fiberglass 100  
With Internal Heater



External Width  
100 CM



Height  
105 CM



Internal Width  
87 CM



1x



25 KW



Color shown is approximate and may vary in person



Cream White



Slate Grey



Sky Blue



Metallic Grey



# MEASUREMENTS

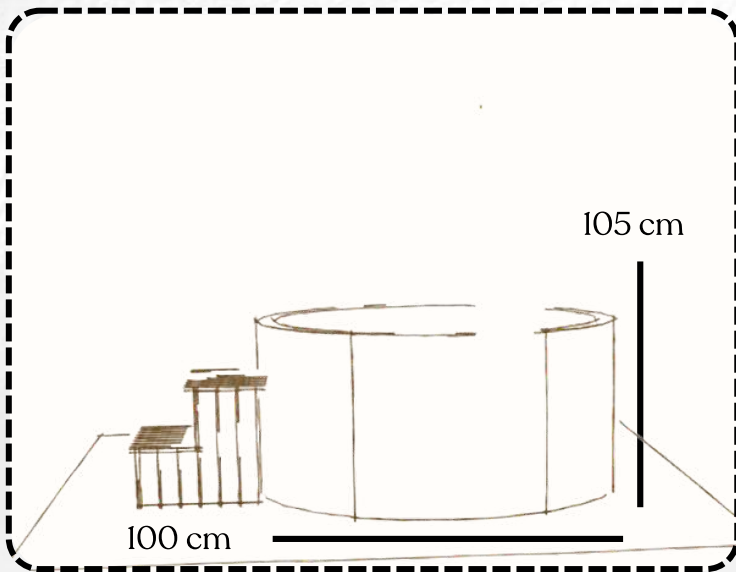
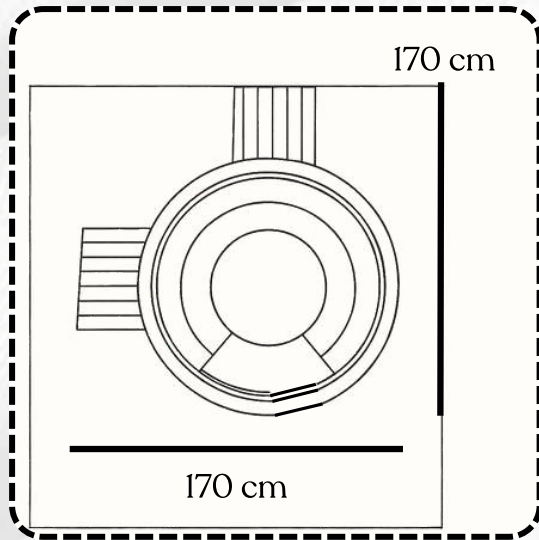

# ACCESSORIES

## DESIGN

Plastic Doors



Stainless Steel Doors



Wooden Shelf\*



Plastic Shelf



\*Only for thermowood and spruce facade hot tubs



Steel Tightening Bands

## WOOD OPTIONS

Untreated



Oil Treatment



Painted



SPRUCE FACADE

Anthracite



Dark Brown



Grey



WOOD PLASTIC COMPOSITE

Untreated



Oil Treatment



Painted

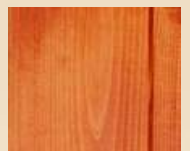

THERMOWOOD

## STAIR MODELS

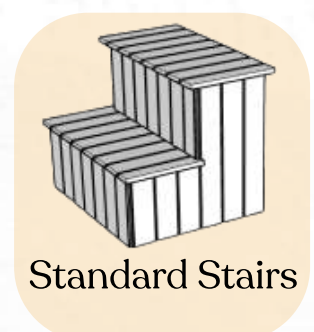

# WATER TREATMENT

## Filter Connections



Stainless steel connections for external filtration systems provide a durable and reliable solution for integrating a sand filter into your hot tub, ensuring optimal water cleanliness and longevity.

## Filter For Sand Filtration



The sand filter system keeps hot tub water clean and clear. It can be filled with special filtration sand or cotton balls for efficient water purification. The system includes a dedicated water pump and a large particle filter for optimal performance.

## UV-C Lamp ( Blue Lagoon)



We use Blue Lagoon UV lamps, the world's leading brand, in our hot tubs. These UV-C lamps are specially designed to withstand high water temperatures, ensuring efficient and safe water disinfection. The UV radiation neutralizes bacteria, viruses, and other microorganisms, preventing their growth and keeping your hot tub water crystal clear.

To reach best results use together with filter system.

## Electric Heaters



3 KW Electric Heater

6 KW Electric Heater

9 KW Electric Heater

The electric heater enhances hot tub versatility, working alongside the wood-fired heater to maintain the desired temperature after initial heating. In winter, it helps prevent water from freezing, ensuring year-round usability and convenience.

## Filter Box



The filter box securely encloses the filtration system, ensuring a clean and organized setup. Made from the same material as the hot tub façade, it maintains a seamless, unified look. The box also provides space for an additional electric heater and a UV-C lamp, allowing easy access to these essential components for maintenance and upgrades.



Spruce Filter Box  
Thermowood Filter Box  
WPC Filter Box

## Gecko Spa System With 3 KW Electric Heater

A complete SPA system with an integrated electric heater and smart control module transforms your hot tub into a fully automated experience. Powered by Gecko, one of the world's leading SPA system manufacturers, the controller allows you to easily manage temperature, massage functions, lighting, and more, ensuring ultimate comfort and convenience.



## Gecko IN.K300



- LCD Screen – Clear display for easy control.
- Temperature Control – Adjust and maintain water temperature.
- Water-Care Modes – Program filtration and maintenance cycles.

## Gecko IN.K1000



- Touchscreen Interface – 4.3" capacitive screen with color display.
- Customization – Control lighting, audio, and accessories.
- Wi-Fi Support – Remote spa management via in.touch 2 module.